

OLYMPUS STEREO MICROSCOPES

INSTRUCTION MANUAL

MODELS VMF, VMT & VMZ

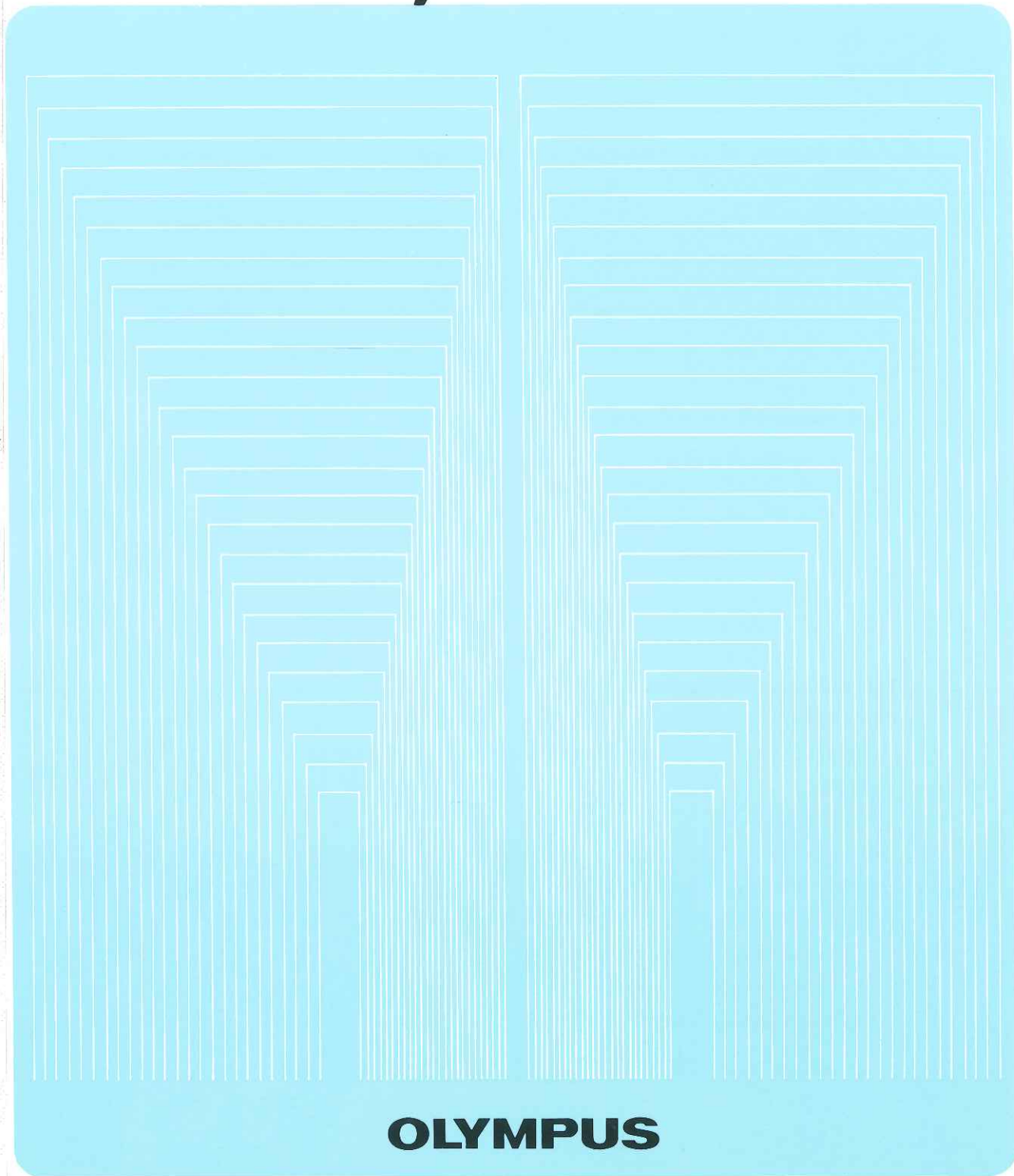

OLYMPUS

This instruction manual has been written for the use of the Olympus Stereo Microscopes Models VMF, VMT and VMZ. It is recommended that you read the manual carefully in order to familiarize yourself fully with the use of the microscope so that you can obtain optimum performance.

IMPORTANT

■ Operation

1. Always handle the microscope with the care it deserves and **avoid abrupt motions.**
2. Avoid exposure of the microscope to **direct sunlight, high temperature, high relative humidity, dust and vibration.**

■ Maintenance

1. Lenses must always be kept clean. Fine dust on lens surfaces should be blown or wiped off by means of an air blower or gauze. Carefully wipe off oil or fingerprints deposited on the lens surfaces, with gauze moistened with a **small** amount of xylene, alcohol or ether.
2. Do not use organic solutions to wipe the surfaces of various components. Plastic parts, especially, should be cleaned with a neutral detergent.
3. **Never disassemble** the microscope for repair.
4. The microscope should be stored in its container immediately after use. If this is not possible, it should be covered with the vinyl dust cover provided. It is best to keep lenses in a desiccator, containing silica gel.

CONTENTS

	Page
I. MAIN CHARACTERISTICS	1
II. STANDARD EQUIPMENT	1
III. IDENTIFICATION AND FUNCTION OF VARIOUS COMPONENTS	2
IV. ASSEMBLY	3
V. OPERATION	4
VI. OPTICAL DATA	6
VII. USE OF OPTIONAL ACCESSORIES	7
A. Auxiliary Lenses VM-AL 0.5X, VM-AL 0.75X, VM-AL 1.5X and VM-AL 2X	7
B. Simple Polarizing Filter Set VM-POL	7
C. Incident Illuminator VM-LSG	8
D. Mounting Bracket VM-STI	8

I. MAIN CHARACTERISTICS

The VM Series Stereo Microscopes include three types of stereomicroscope bodies — VMF, VMT and VMZ. The Model VMF is provided with one objective pair built into the binocular stereomicroscope body, and the Model VMT with two parfocal objective pairs in a turret built in the microscope body, while the Model VMZ features a continuously variable zoom system objective control in the body.

1. Model VMF

Microscope body	Objective
VMF-1F	1X
VMF-2F	2X
VMF-4F	4X

2. Model VMT

Microscope body	Objective
VMT-2F	1X – 2X
VMT-4F	1X – 4X

3. Model VMZ

Microscope body	Objective in zoom system
VMZ-4F	1X – 4X

II. STANDARD EQUIPMENT

Component		VMF-						VMT-				VMZ-	
		1-S	1-SA	2-S	2-SA	4-S	4-SA	2-S	2-SA	4-S	4-SA	4-S	4-SA
Binocular stereomicroscope body	with built-in objective 1X VMF-1F	○	○										
	with built-in objective 2X VMF-2F			○	○								
	with built-in objective 4X VMF-4F					○	○						
	with objectives 1X–2X in turret VMT-2F							○	○				
	with objectives 1X–4X in turret VMT-4F									○	○		
	with zoom system objective 1X–4X VMZ-4F											○	○
Standard stand	VM-STA	○	○	○	○	○	○	○	○	○	○	○	○
Widefield eyepieces GW10X, paired		○	○	○	○	○	○	○	○	○	○	○	○
Stage plates	Clear glass plate	○	○	○	○	○	○	○	○	○	○	○	○
	Black and frosted white plastic plate	○	○	○	○	○	○	○	○	○	○	○	○
Stage clips, paired		○	○	○	○	○	○	○	○	○	○	○	○
Eyeshields, paired		○	○	○	○	○	○	○	○	○	○	○	○
Reflected and transmitted illumination base VM-ILA			○		○		○		○		○		○
Vinyl dust cover		○	○	○	○	○	○	○	○	○	○	○	○

III. IDENTIFICATION AND FUNCTION OF VARIOUS COMPONENTS

The photo below shows the Model VMT-2-S.

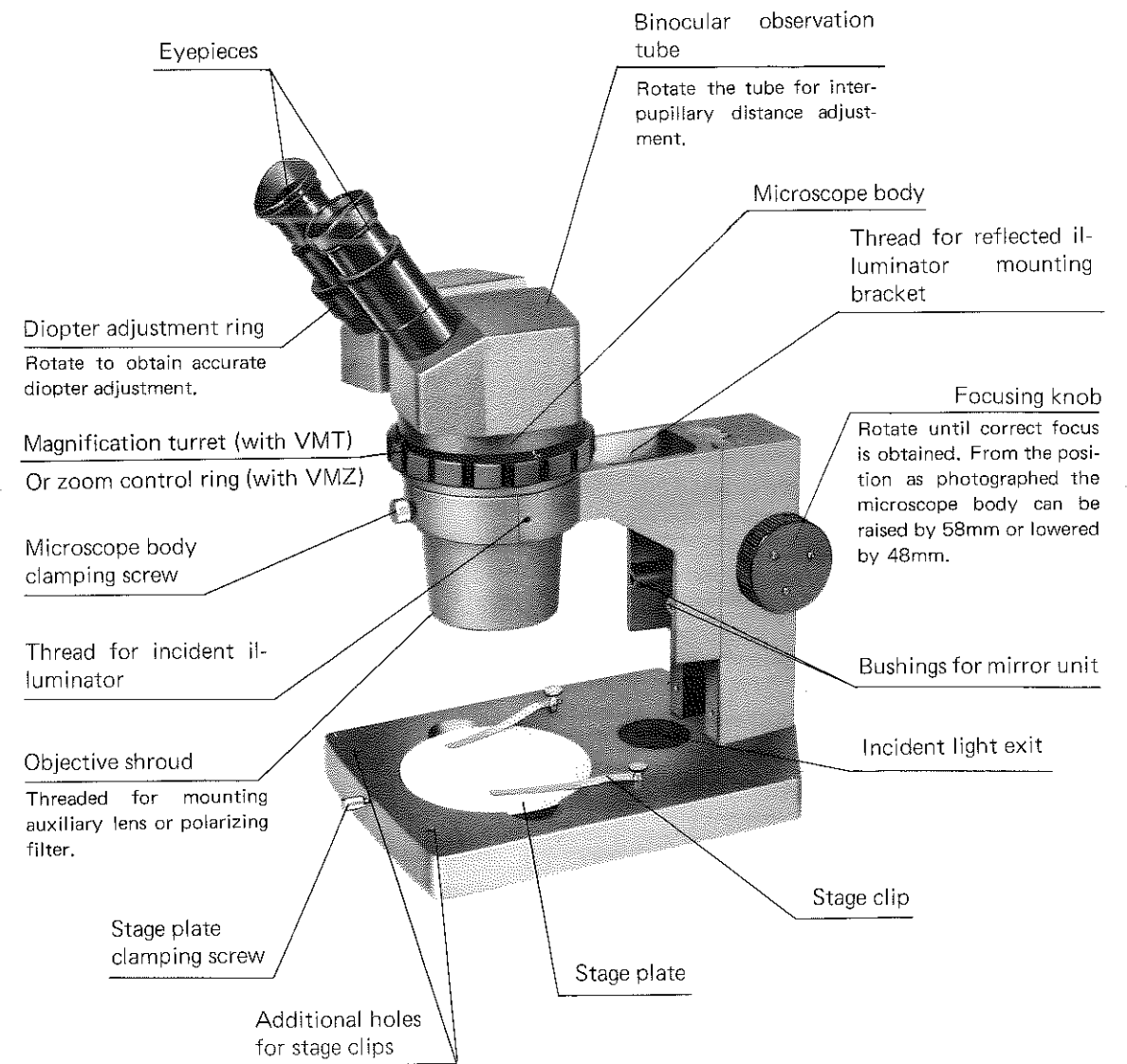

Reflected and Transmitted Illumination Base VM-ILA

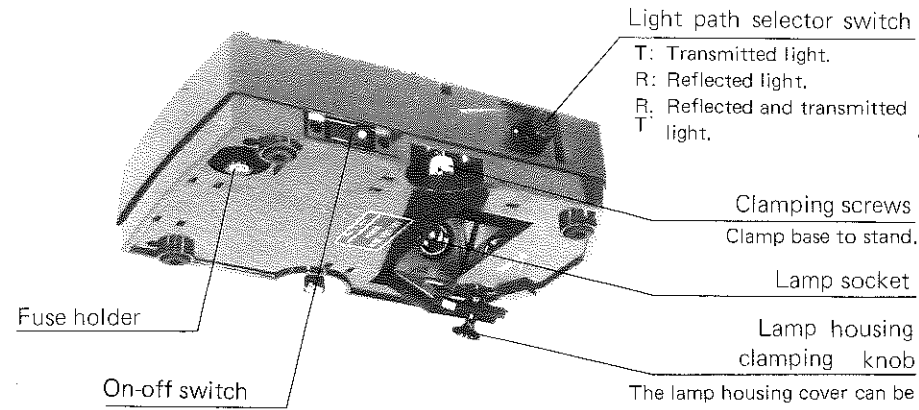

The lamp housing cover can be opened by pulling down the knob; or closed by pushing it up until it snaps in place. Before pushing, ascertain that the knob is positioned as shown in the picture below right, marked with circle.

Mirror unit

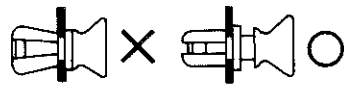
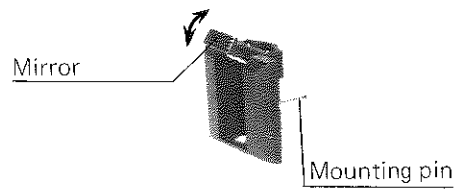

IV. ASSEMBLY

The picture below illustrates the sequential procedure of assembly. The numbers indicate the assembly order of various components.

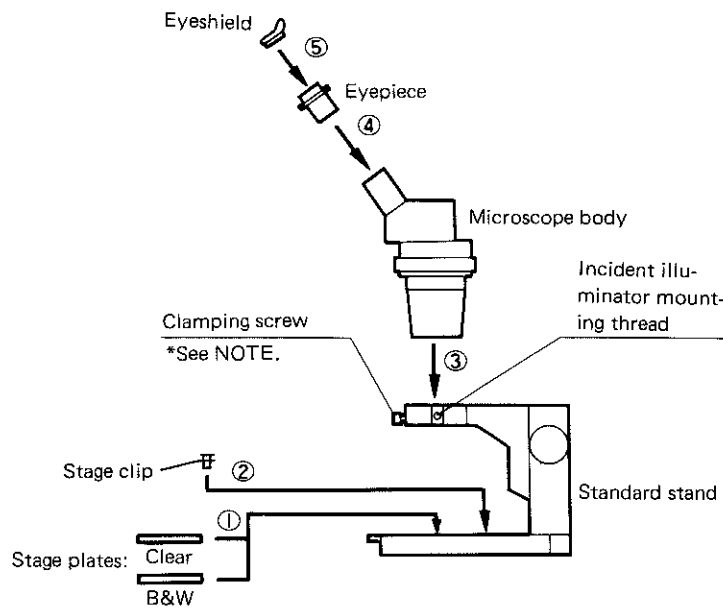

***NOTE:**

As this screw can also be used at the incident illuminator mounting thread, you can choose a better position for mounting the incident illuminator so that it does not block your smooth operation.

V. OPERATION

The stage plates fit into the circular opening in the base. The clear plate can be used for both reflected and transmitted illumination. Colored background can be achieved by placing suitable material beneath the plate, for contrast, etc. The frosted plate is used with reflected illumination. The plate is frosted white on one side, and black on the other. If the specimen is white or brightly colored, use the black side of the plate to increase image contrast by darkening the background. For dark or black specimens, reverse the plate with the white frosted side facing the objective.

1. Tension Adjustment of Focusing Knobs

This focusing mechanism makes its motion freely adjustable for either heavy or light movement depending on the observer's preference. To adjust the tension hold the two focusing knobs with both hands and slightly rotate them in the opposite directions, at the same time. (Fig. 1)

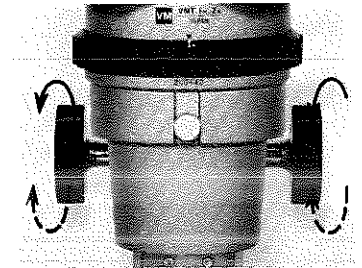

Fig. 1

2. Specimen on the Stage Plate

Place a specimen in the center of the stage plate and clamp it with the stage clips, if necessary. (Fig. 2)

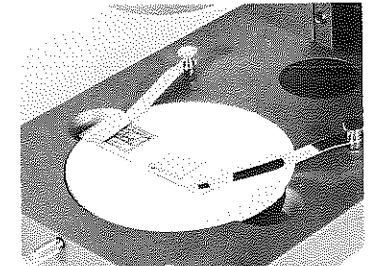

Fig. 2

3. Interpupillary Distance Adjustment

Hold the right and left eyepiece tubes with both hands and push or pull the tubes in the arrow directions until perfect binocular vision is obtained. (Fig. 3)

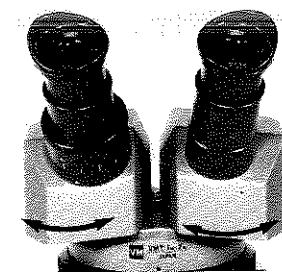

Fig. 3

4. Diopter Adjustment

a) Looking through the right eyepiece with your right eye, focus on the specimen with the focusing knobs.

NOTE: In case of the Model VMT or Model VMZ, ascertain that the high magnification objectives are used for this adjustment.

b) Look at the image through the left eyepiece with your left eye, and rotate the diopter adjustment ring ① to focus on the specimen, without using the focusing knobs. (Fig. 4)

NOTE: If accurate interpupillary distance and diopter adjustments are not accomplished, prolonged observation would put considerable strain on the observer's eyes.

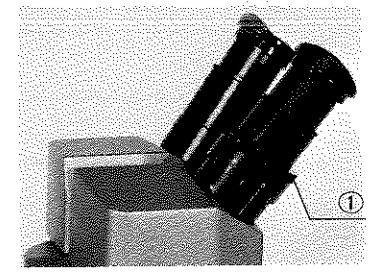

Fig. 4

5. Objective Changes

The Model VMT is provided with two objective pairs. Rotate the turret until the objective pair of your choice is engaged.

In case of the Model VMZ, rotate the zoom control ring until you obtain the desired magnification within the magnification range.

6. Use of Eyeshields

Eyeshields are recommended to prevent glare and loss of contrast caused by ambient light hitting the eye.

7. Use of the Reflected and Transmitted Illumination Base VM-ILA

- a) Water sealed light exits on the base prevent damage from water spills.
- b) It provides even illumination with all objective powers except the auxiliary lens VM-AL 0.5X.
- c) If light intensity is too high, it can be reduced by placing a 45mm-diameter ND filter on the light exit on the base.
- d) Setup.

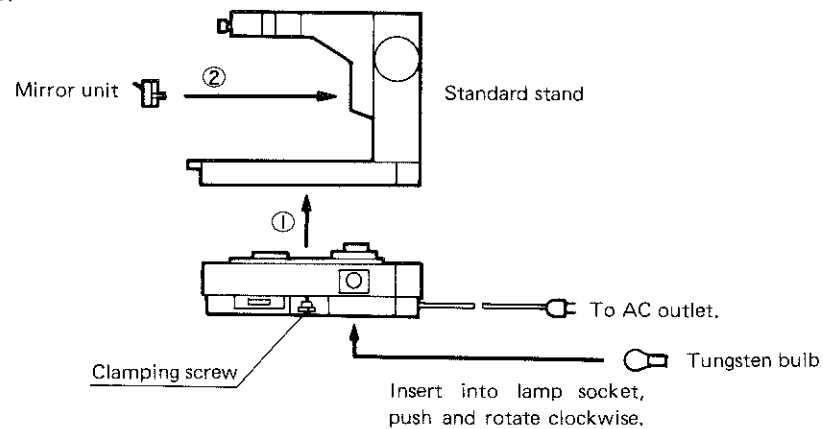

- e) Use.

1) Activate the on-off switch ① .

2) Set the light path selector switch ② .

T: Transmitted light. Use clear stage plate.

R: Reflected light via mirror unit. Adjust the mirror ③ so that the light hits the center of the stage plate.

$\frac{R}{T}$: Combination reflected and transmitted light.

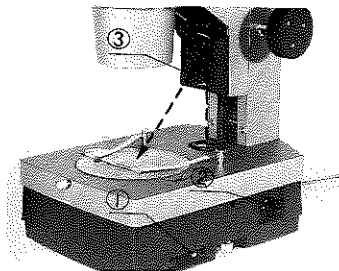

Fig. 5

VI. OPTICAL DATA

■ Models VMF and VMT

Objectives		Eyepieces							
		GW10X (Field number 22)		*GWH10X(23)		G15X(13)		G20X(12.2)	
				Optional					
		*Total magnif.	*Field of view	Total magnif.	Field of view	Total magnif.	Field of view	Total magnif.	Field of view
1X	*W.D. 90mm	10X	22mm	10X	23mm	15X	13mm	20X	12.2mm
2X		20X	11mm	20X	11.5mm	30X	6.5mm	40X	6.1mm
4X		40X	5.5mm	40X	5.75mm	60X	3.25mm	80X	3.05mm

■ Model VMZ (Data below are obtained at zoom magnification setting positions)

Objective (Zoom magnif. 1X to 4X)		Eyepieces							
		GW10X (Field number 22)		*GWH10X(23)		G15X(13)		G20X(12.2)	
				Optional					
		*Total magnif.	*Field of view	Total magnif.	Field of view	Total magnif.	Field of view	Total magnif.	Field of view
1X	*W.D. 90mm	10X	22mm	10X	23mm	15X	13mm	20X	12.2mm
2X		20X	11mm	20X	11.5mm	30X	6.5mm	40X	6.10mm
3X		30X	7.33mm	30X	7.67mm	45X	4.33mm	60X	4.07mm
4X		40X	5.5mm	40X	5.75mm	60X	3.25mm	80X	3.05mm

*REMARKS

GWH10X: Widefield high eyepoint eyepiece.

W.D.: Working distance between specimen and objective front lens.

Total magnification = Objective power x Eyepiece power

Field of view diameter = $\frac{\text{Field number of eyepiece}}{\text{Objective power}}$

VII. USE OF OPTIONAL ACCESSORIES

A. Auxiliary Lenses VM-AL 0.5X, VM-AL 0.75X, VM-AL 1.5X and VM-AL 2X



VM-AL 0.5X



VM-AL 0.75X

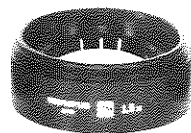

VM-AL 1.5X

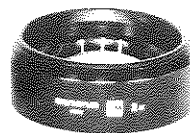

VM-AL 2X

When threaded into the objective shroud, each of these auxiliary lenses permits change of total magnification without changing objective or eyepiece.

Auxiliary lens	*VM-AL 0.5X	VM-AL 0.75X	VM-AL 1.5X	VM-AL 2X
W.D.	156mm(6.14")	101mm(4")	43mm(1.7")	29mm(1.14")

Total magnification = Objective power x Eyepiece power x Auxiliary lens power

Field of view diameter in mm = $\frac{\text{Field number of eyepiece}}{\text{Objective power} \times \text{Auxiliary lens power}}$

***NOTE:** The VM-AL 0.5X requires an extension tube (VM-ET) in conjunction with the standard stand because of its considerably long working distance. After screwing the VM-AL 0.5X into the objective shroud, attach the extension tube in position between the objective shroud and the standard stand as illustrated right:

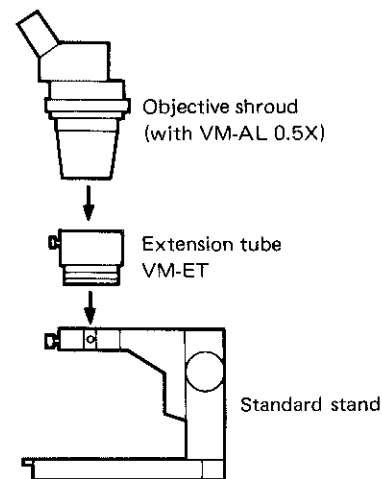

B. Simple Polarizing Filter Set VM-POL

This unit enables observation of birefringent material in transmitted light.

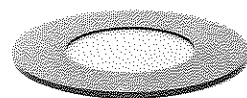

Polarizer

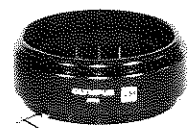

Analyzer

Rotation knob

Insert the polarizer into the base opening beneath the stage plate, aligning the white dot to the recess in the opening edge, and screw the analyzer into the threaded objective shroud. Rotate the analyzer rotation knob, looking through the eyepieces, until extinction is achieved.

C. Incident Illuminator VM-LSG

The Model VM-LSG is connected to the transformer TL and can be inserted into the microscope stand or clamped to the transformer by means of a jointed bracket for incident illumination.

a) Setup.

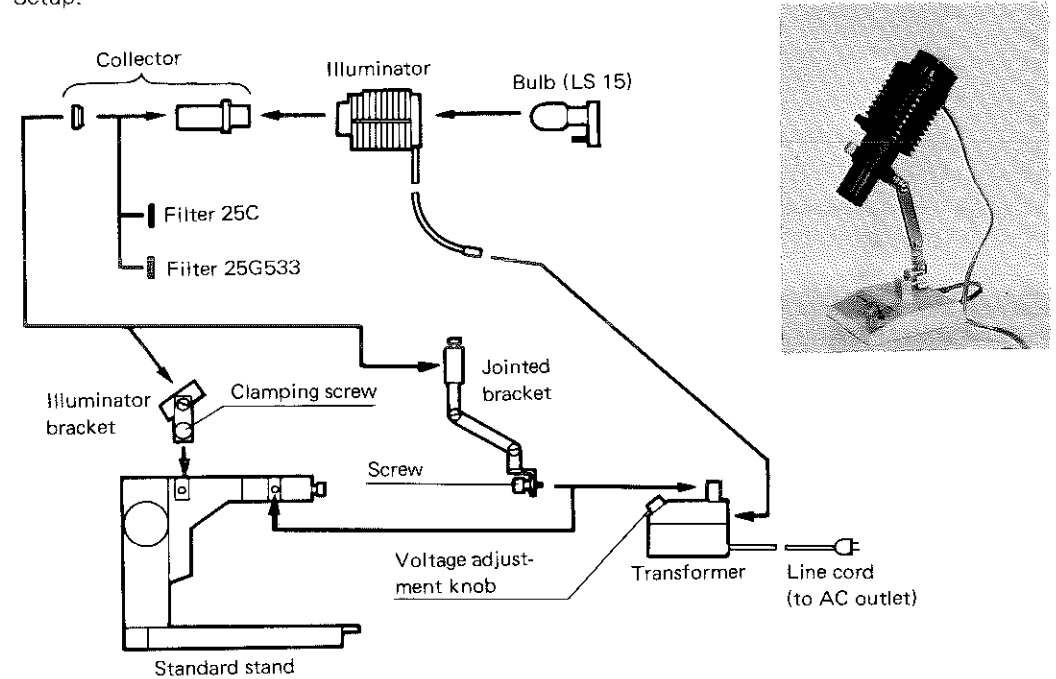

b) The light intensity of the incident illuminator is adjusted by means of the voltage adjustment knob on the transformer.

c) A daylight filter 25C and a green contrast filter 25G533 are provided.

D. Mounting Bracket VM-STI

Permits mounting of the microscope body to the universal table stands Models VS-4, VS-5 or on a custom mounting post on any machine or instrument you own or manufacture, through the 24.5mm diameter opening.

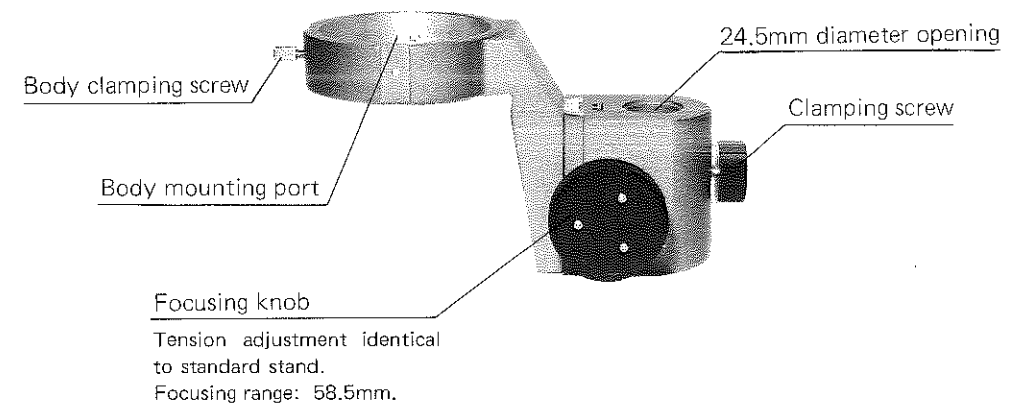

OLYMPUS OPTICAL CO., LTD.  **SAN-EI BUILDING, 22-2, NISHISHINJUKU
1-CHOME, SHINJUKU-KU TOKYO, JAPAN.**

